

世界量產最低電量、超迷你散熱扇

超低電量微米扇 DC ATOMIC COOLER

Ultra-Low
Power

特點 FEATURES

- ✚ 超小/超薄，適用小型手持電子裝置
- ✚ 超低耗電量
 - ✚ 超低噪音
 - ✚ 自潤軸受. 壽命長
- ✚ Extra mini and slim, extremely suitable for portable Electronic devices
- ✚ High efficiency and low power
 - ✚ Low noise
 - ✚ Self-lubricative bearing used for a long service life

RFA1504DU

15*15*4mm



適用產品 APPLICATIONS

手腕錶式動態氣流品質監測應用、溫控輔助應用、隨身型迷你投影機

Wearable dynamic air quality sampling applications, auxiliary temperature control applications, and portable mini projector.

尺寸 DIMENSIONS

(單位 unit : mm)

➤ RFA1504DU

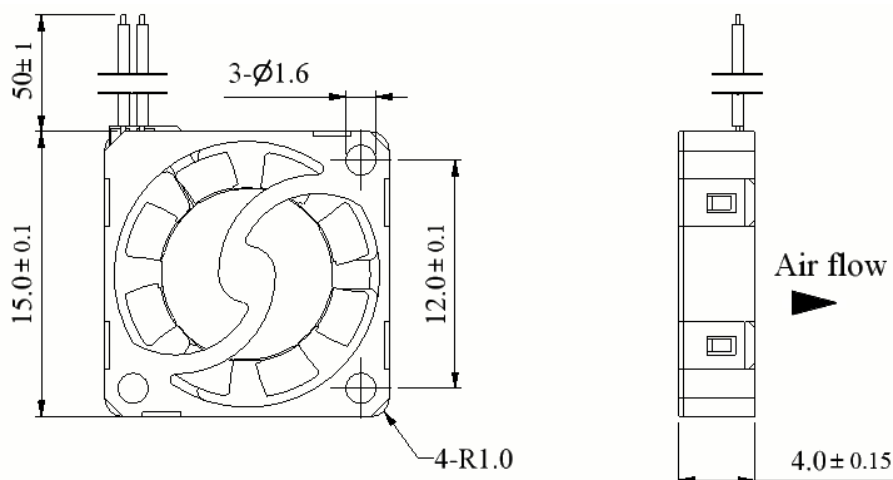

規 格 SPECIFICATIONS

型 號 Model Number	RFA1504DU
品 名 Product Name	超低電量微米扇 Ultra-low Power Atomic Cooler
軸 承 Bearing	軸射軸承 Axially-grooved Bearing
額定電壓 Rated Voltage (VDC)	2.4
運轉電壓 Operating Voltage (VDC)	2.4~3.3
額定電流 Rated Current (mA)	8
轉 速 Rotation Speed (RPM)	5,000
風 量 Air Flow (CFM)	0.07
靜 壓 Static Pressure (mmAq)	0.21
噪 音 Noise (dB(A))	20
重 量 Weight (g)	1.7

規格視實際情況更動，不作另行通知 Specifications subject to change without notice

運轉環境溫度 Operating Temperature : -10 ~ +60°C

風量-靜壓圖 PERFORMANCE CURVE

➤ RFA1504DU

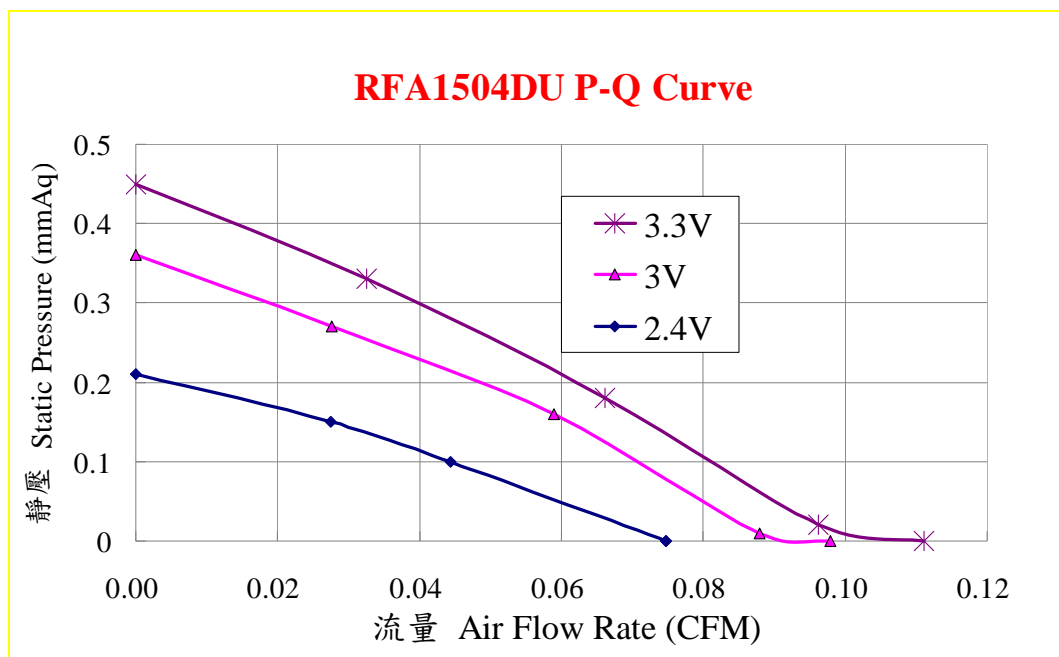

飛安電氣有限公司 sales@faan.com.tw